

# ***Sierra Radio Systems***

Applications Note AN3

Interfacing the Series 200 control systems to a  
Motorola Maxtrac radio

Version 1.0  
April 2006



# Interfacing to the Motorola Maxtrac



## **Introduction**

The Motorola Maxtrac is a popular radio because of its small size, good performance and modest price. In a full duplex environment, two radios are required, one for receive and one for transmit. The Maxtrac easily interfaces with the Series 200 control system. This app note describes how to interface the Maxtrac to the control system either using the SRS RIO-II interface board or via direct connection to the control system. This app note does not discuss any internal modifications required or programming software necessary to configure a particular radio to operate on the desired frequency. There are many resources on the web that can help you in getting the radio on the desired operating frequency and tone.

Maxtrac radios have either a 5 or 16 pin accessory connector on the back. SRS provides a complete interface kit to connect the control system to a pair of Maxtrac radios. The 16 pin Maxtrac can be configured to deliver all necessary connections to the connector. The necessary signals are

- Receive audio out (unsquelched)
- Transmit audio in
- COR out (receive signal present indication)
- COR & PL/DPL decode out
- PTT in ("Push To Talk)
- Ground

Note: the audio in and out is actually considered flat only in that the radio does not alter what comes in. In other words, a transmitted FM signal, over the air is pre-emphasized and the rx audio out does not alter this. Therefore, the audio out of the radio and routed through the control system is pre-emphasized. When the controller drives the Maxtrac transmitter, the "flat" modulator input does not alter the frequency response so pre-emphasized audio from the controller is transmitted as pre-emphasized over the air. In this way, the "flat" maxtrac rx and tx just takes the pre-emphasized audio in, routes it to the transmitters and re-transmits pre-emphasized audio. This means that the original mobile transmitter pre-emphasizes the audio and the final receiving mobile radio de-emphasizes the audio and everything is fine.

The other important note is that any device that plugs into the controller that normally uses true flat audio like a computer for IRLP, EchoLink or other VOIP applications or a remote base radio like an Icom, Kenwood or Yaesu requires the received audio to be pre-emphasized and the tx audio for that port to be de-emphasized. This can be achieved either with an external board like the AS-2 or RIO-II or with a few component changes on the RCB.

To pre-emphasize rx audio, replace R24 with a 3.3k and 75k resistor in series with a 0.01 uf cap across the 75k resistor as it enters the op amp. Add a 4700pf cap to position C9 for transmitter de-emphasis.

In the most simple case, interfacing the Maxtrac radios only requires building a cable that connects from the control system (DB9-M) on one end and splits into two connectors (AMP) on the other end, one going to the receiver and one going to the transmitter.

The control system provides the necessary receive audio gating and the control system assumes flat audio in and out so no external active components are necessary. To make the installation easy, SRS offers a Maxtrac interface kit that allows almost plug-n-play ease of installation.

# RIO-II Configuration for the Motorola Maxtrac

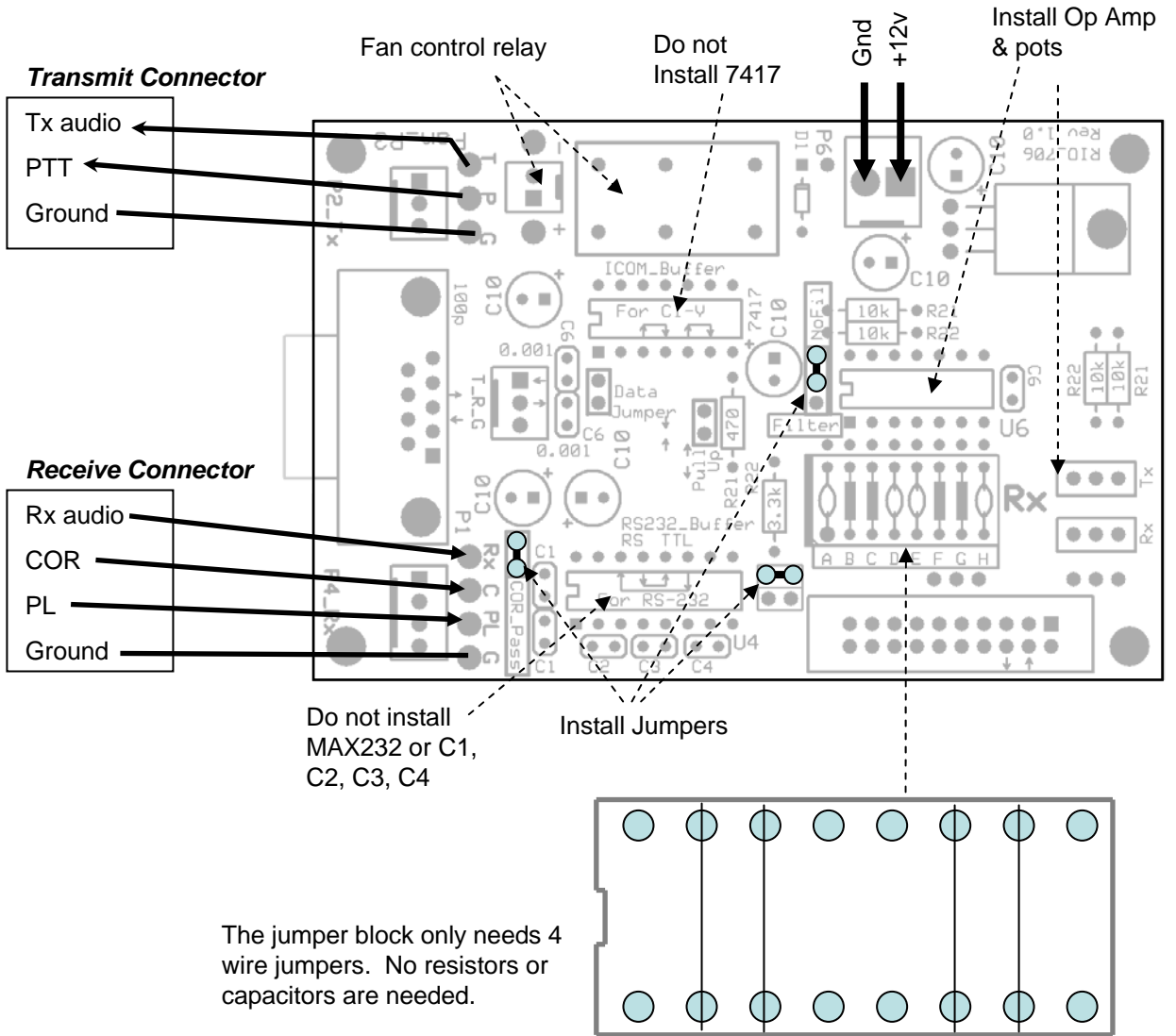

# Schematic

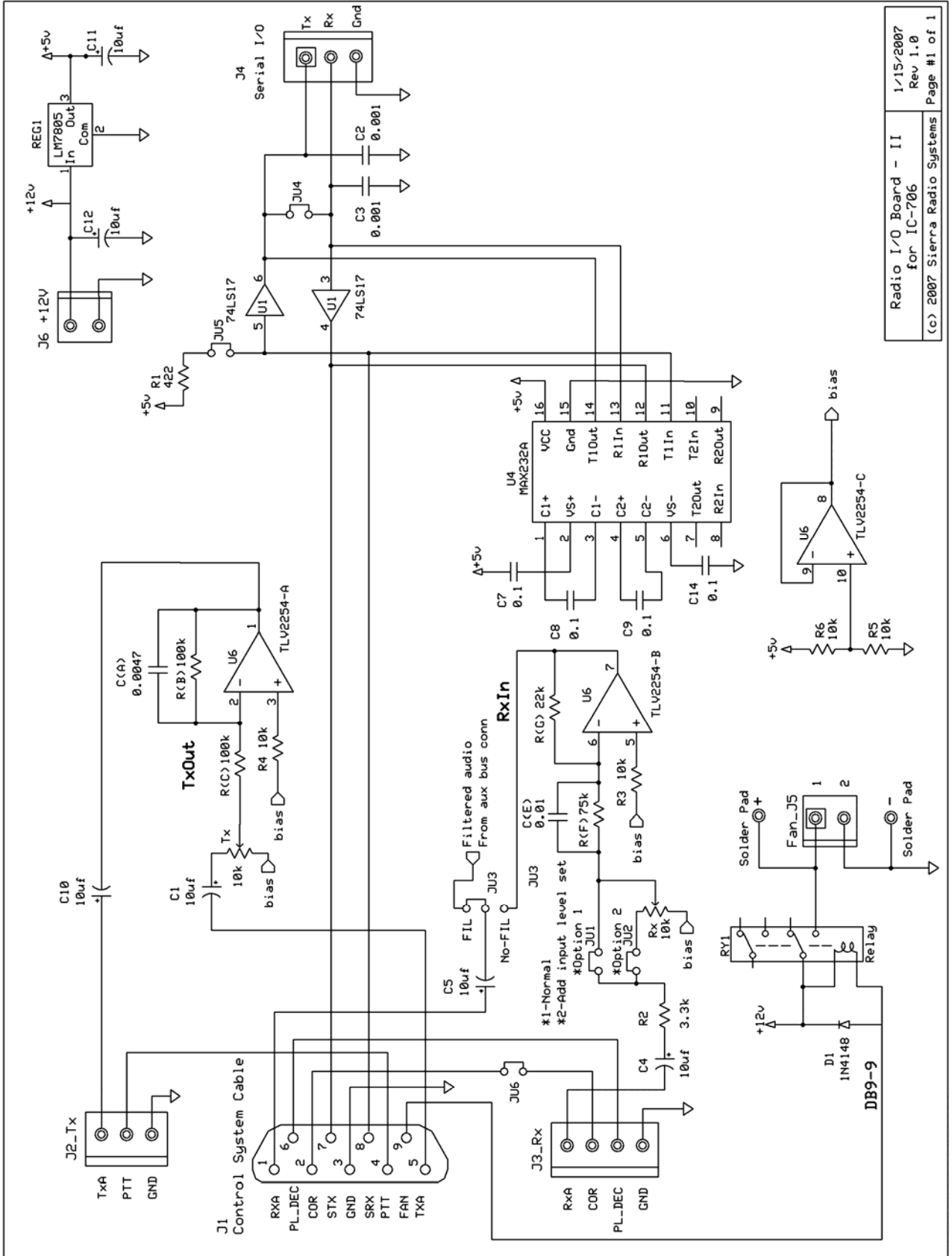

AN3 - Interfacing to a Motorola Maxtrac radio.

# Recommended Standard 16 Pin Connections

## Assign pins in the RSS under "General I/O"

Pin	Function	Notes
1	External Speaker minus (-)	Not used in repeater/link configuration
2	Mic audio	Not used in repeater/link configuration
3	PTT	Active low
4	External Alarm	Not used in repeater/link configuration
5	Flat TX audio in	Use with AS-1
6	Not used	Programmable pin
7	Ground	
8	Carrier Squelch detect	Active low (programmable pin)
9	Not used	Not used in repeater/link configuration
10	Not used	Can be used as Ignition Control in mobile application
11	RX Audio	Buffered detector audio
12	Carrier Squelch Plus PL detect	Active low (programmable pin)
13	Switched A+ Sense	Not used in repeater/link configuration
14	Not used	Programmable pin
15	Internal Speaker plus (+)	Connect to Pin 16 to use internal speaker
16	External Speaker plus (+)	Not used in repeater/link configuration

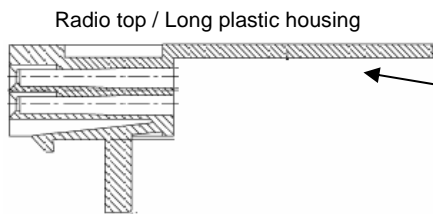

Connector, with locking tab 16 pin, (AMP 104422-1)  
Digikey # 104422-1-ND

Contact, (AMP 1-87309-3) Digikey # A3007-ND

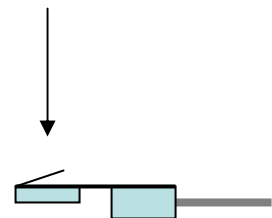
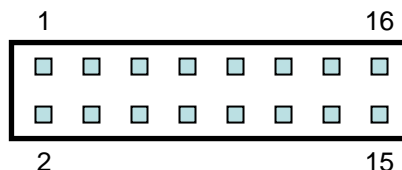
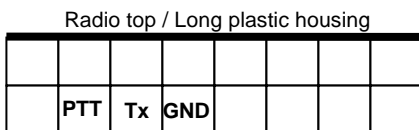
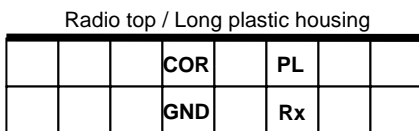

Rear view of the Maxtrac radio showing the 16 pin accessory connector.