

Sierra Radio Systems Controller Software and Configuration Manual

Version 0.96

March 7, 2008

Getting Started

To get on the air with the simplest possible linked repeater configuration, just take the following steps:

1. Following the instructions in the SRS Series 200 Hardware Manual, configure the hardware
2. Optionally, connect a computer to the CPU board serial port connector, using a female/female straight-through cable (beware, most female/female cables are not straight through and swap pins 2 and 3 between the two connectors).
3. Turn on the system.
4. Transmit to the repeater input. Unless the system has already been configured with a more complex configuration, the repeater and all of the links transmitters should turn on, and the repeater port should send a CW identifier (the default is "NO ID", which is what you will get if the system has not already been configured).
5. Basic configuration can be done via DTMF transmitted to any of the receiver inputs, but it is much easier to do it via the serial port. So, if available, configure the computer's serial port for 9600 baud, 8 bits, no parity, and no handshaking.
6. Using either a terminal emulator, or the Sierra Radio Systems configuration software, define the unlock codes for executing protected commands; and define the ID string, location string, and prefix (used for commanding the controller from one of the links). See the **Basic Configuration** section below for instructions on how to do this.
7. You will probably want to adjust the input and output gain of the controller to get the deviation correct at each of the transmitters. This should be done next. See the **Level Adjustment** section below for instructions on how to do this.

Introduction

In order to configure the Sierra Radio Systems model 200 repeater controller for operation at a specific site, it is helpful to have an understanding of the overall architecture of the controller and the embedded software that makes it run.

Table 1 provides a set of definitions for the terms used in this manual.

| | |
|------------------|---|
| Backplane | The circuit board into which all of the other circuit boards are plugged in. It is passive (no active silicon devices) and wires all the other circuit boards together. |
| CPU Board | The circuit board plugged into the backplane which contains the microprocessor which runs the main program controlling all of the operations |

| | |
|---|---|
| | of the controller. |
| Radio Control Board | One of the circuit boards plugged into the backplane, which provides the interface between the controller and a radio transmitter and receiver combination or any other audio signal source and destination, such as an IRLP node or telephone interface. |
| Port | Generic term for one full duplex connection to the controller. This could be a repeater, a link to another site, and IRLP node, or a remotely controller transceiver (remote base). |
| Physical Port Number | The Radio Control board farthest to the left in the card cage, and next to the CPU board is designated physical port number 0, the Radio Control board immediately to the right of physical port number 1, and so on. |
| Logical Port Number | Users need to control the system by commanding specific ports, using the port number. For example, the user may want to disconnect Link 1 at the San Francisco Bay area Black Mountain site which links to another site at Crystal Mountain. He would issue the Link 1 OFF command to do this. There may be situations where the port number that a user associates with a particular link cannot be the same as the physical port number. As a system grows, or if there is a problem with the hardware for one of the links, it is undesirable to change the logical port number for a link to some particular other site, but it may be necessary to change the physical port number attached to that link. The controller provides a logical to physical port mapping that can be used to make the logical and physical port numbers different. |
| Repeater or Local Radio or Repeater Port | A port which is configured to operate as a repeater. Signals coming in on its receiver will be repeated back out its transmitter. |
| Link or Link Radio or Link Port | A port which is configured to operate as a link. Signals coming in on its receiver will not normally be repeated back out its transmitter, but only to other ports which are connected ("linked") to this port. |
| IRLP Port | A port which is configured to operate as a restricted link, normally used for IRLP or other voice over IP connections into the site. |
| Remote Base Port | A port which is configured to operate a remotely controlled transceiver. It invokes special telemetry, and is most commonly used in a simplex mode. The v0.90 software has limited support for this type of port. |
| Unlock code and Super-unlock code | Many controller commands cannot be executed until an unlock code is entered. This prevents unauthorized users from reconfiguring the system. There are up to 20 unlock codes, which are designated unlock code number 0 to 19. There are two levels of unlock code, designated unlock code and super-unlock code. Unlock codes 0 and 1 are super-unlock codes. The rest are just unlock codes. A few commands require the super-unlock code, including the commands to change the unlock code table, commands to force reloading of default parameters, and commands to backup and restore the EEPROM parameter sets. |
| Group | A set of ports which are normally linked together, independently from ports which are members of a different group. Definition of groups allows the controller to manage several semi-independent repeaters. Group membership can be changed dynamically give great flexibility in connecting different |

radios together in different ways.

Figure 1 shows an overall block diagram of the controller. The basic controller functions are executed by two kinds of cards which are plugged into the controller backplane. Overall operation of the controller is managed by the “CPU Board.” The interface to each radio (or other signal source such as a voice over IP node or telephone connection) is managed by a separate “Radio Control Board” for each port.

Figure 1 goes here

The Rev 1.0 CPU board contains a Microchip 18F8722 microcontroller. Earlier, beta, versions of the hardware used a Microchip 18F4620 on this card, which has one-half the program memory space of the 18F8722.

The Rev 1.0 Radio Control board contains a Microchip 18F4620 microcontroller. Earlier, beta, version of the hardware used a Microchip 18F452 on this card, which has one-half the program memory space of the 18F4620.

The embedded software running on these processors is programmed in a combination of C and assembler. The Microchip C18 compiler and MPLAB IDE and assembler were used to develop the code.

Hardware Details

CPU Board

In addition to the processor, the CPU board contains hardware with the following functions:

- 64kB serial eeprom for configuration storage
- 2 wire serial interface (I²C) to communicate with the processors on the Radio Control boards and with the serial eeprom
- high speed serial interface dedicated to reading COR, PL, and DTMF status from the Radio Control boards
- high speed serial interface dedicated to controlling the PTT, fan relay, audio multiplexer, and general purpose i/o lines on the Radio Control boards
- standard serial port (RS-232) for external computer connection to provide control, configuration, and (not yet implemented) firmware download
- 4 channel tone generator, routed to the backplane, used to generate control response telemetry
- digital pot to set maximum tone generator telemetry level
- CPU programming connector

Radio Control Board

In addition to the processor, the Radio Control boards contain hardware with the following functions:

- audio and control line (COR, PL, PTT, dtmf decode) interface to transmit and receive radios

- audio mixer/switch to select any combination of back plane audio to route to the transmitter
- buffer to drive audio from this board to the back plane
- 4 channel tone generator, used to generate ID's, key up telemetry, and busy signals
- digital pots to control receive input gain, maximum tone generator level, PL level (not currently used), and transmit level
- port selection jumpers
- dtmf decoder

Commands

The system is controlled using commands which are sent to the controller by DTMF tones transmitted to one of the receivers connected to the controller, or by the RS232 serial port on the CPU board.

Built-in Commands

There is a large set of built-in commands that can be used set up and manage the repeater system connected to the controller. These commands start with a "C", or "S", and will generally not change from one version of the controller software to the next. To prevent unauthorized users from changing everything in the controller, most of these commands require that an unlock code be entered before the command will be accepted. In the v0.90 beta software the built-in commands and command names cannot be changed by a user or site administrator.

Macros

Commands that are designed to be used for everyday control of the system are implemented as macros. Macros are just lists of built-in commands or other macros which get executed in sequence when the macro is called. The macros can be defined to require entry of an unlock code, or to be executable by anyone with knowledge of the command code which executes a particular macro.

Macros are called in one of two ways. There is a built-in command which takes the macro number to be executed as a parameter. It is possible to invoke any macro by calling this command. There are a set of predefined command names, 000 to 099, and C800 to C849, each of which force execution of a specific macro. The default contents of these macros are empty, so you are free to define them with the sequence of commands of your choice. There is also a set of built-in commands and associated default macro definitions for the most common user level commands. These are documented in a separate document, "Default Command Macros." In the v0.90 beta software, the contents of any macro (eg., which built-in commands the macro executes) can be changed by the site administrator, but the set of commands which call the macros is fixed in the program and cannot be changed. This is a significant limitation, as it means that the name of a command cannot be changed. Command names will be able to be changed in the v1.00 software.

There is space for 400 macros in the controller, numbered 0..399. Commands "000" to "099" invoke macros 0..99. Commands "C800" to "C849" invoke macros 100..149.

Default user commands are mapped to macros 150..200. Default user command macros are loaded into the table of macros when the controller starts up for the first time. See the command list and default command macro documents for details.

Essential Commands

All of the implemented commands are documented in the document, "SRSC Command List 0094b.doc". A few of the most essential commands are listed here to get started. A (u) or (su) after the command indicates that an unlock or super unlock code must be entered in order for the command to be recognized.

For the most up to date description of these commands, see the SRSC Command List document.

Most Basic System Management

| Code | Operation | Comments |
|-----------|--|--|
| C000 (u) | Reset processor | |
| C001 | Code version | Returns the code version |
| C021 (u) | Radio card software version | Returns the version string for one radio card. Syntax is C021r. r is the physical port number. |
| C100 (su) | Force default configuration load on next processor reset | Sets serial eeprom valid byte to 0, invalidating the eeprom. New eeprom values will be loaded from the hard coded defaults on the next reset. |
| C102 (u) | Configuration backup | The system configuration is stored in a serial eeprom external to the main processor on the CPU board. The serial eeprom has space for 3 copies of the configuration parameters, including the table of macros. They are designated the working set, backup set, and deep backup set. This command copies the working set to the backup set. It should be used after changes are made to the controller configuration and are verified to be working properly. |
| C103 (su) | Configuration restore | Restore configuration from backup set to working set. Most controller operations use values of working parameters stored in RAM on the CPU and Radio Control board processors. To make the restored parameters active, a processor reset (C000) should be done after using this command. |
| C104 (su) | Deep configuration backup | Copy backup configuration set to the deep backup set. This command should be used after the configuration backup command after a new configuration has been thoroughly tested. |
| C105 (su) | Deep configuration restore | Copy deep backup configuration set to backup set. |
| C110 (su) | Set unlock code | Sets unlock code for enabling locked commands. This command requires a super unlock code (code #0 or #1). The unlock code number is returned in |

| | | |
|------------|--|---|
| | | the telemetry if successful. No checking is done for conflicts with commands, so be careful that a command is not the same as the unlock code or is contained in the leading characters of the unlock code. The lowest index blank unlock code is set. Syntax is *C110sssssD. Up to 6 characters can be used (recommended). The terminating D is not used if 6 characters are entered. The unlock code characters must be numeric (0..9); ABCD are not allowed. |
| C111 (su) | Delete unlock code | Deletes the matching unlock code. This command requires a super unlock code. Unlock code #0 cannot be deleted with this command. The unlock code index is returned if successful. Syntax is *C111sssssD. |
| C112 (su) | Delete unlock code index | Deletes a specific unlock code number. This command requires a super unlock code. Unlock code number 0 cannot be deleted. Confirms if an unlock code is deleted. Does not confirm if index is out of range, or no unlock code currently exists at the specified index. Syntax is *C112nnD. There is space for 20 unlock codes, with index 0..19. |
| C113 (u) | Check unlock code | Returns the index of a matched unlock code. Returns nothing if there is no match. Syntax is *C113sssssD. |
| C114 | Set unlock code 0 (no radio control cards) | Sets unlock code 0. No unlock code is required, but all radio control cards must be removed from the controller first. Syntax is *C114sssssD. |
| C115 (su0) | Set unlock code 0 | Sets unlock code 0. Requires unlock code 0 to be used to unlock the controller first. Syntax is *C115sssssD. |

Basic Setup Commands

| Code | Operation | Comments |
|------------------|-----------|---|
| C116 (u) S116 | Set ID | Sets the primary ID string. Syntax is *C116c1c1c2c2c3c3c4c4...D. Each character in the string is defined by two dtmf keys. '2' is specified by "20", 'A' is specified by "21", 'B' by "22", etc. The complete character translation table is included following this command table. If the *C116 command is used from the serial port, spaces may be inserted between characters for clarity (eg. *C116 c1c1 c2c2...<CR>). The S116 version is designed to be used via the RS232 port. It takes the characters directly. All spaces are included. Return terminates the |

| | | |
|------------------|---------------------|---|
| | | string. ! escapes. For example, *S116 kj6k <CR> sets the ID to " kj6k ". This command does not download the new ID to the radio cards. Issue a processor reset (C000) to do this. One or two leading spaces should be included with the ID to give the transmitter enough time to come up before the CW starts; there is no delay in the program. The ID strings can be up to 19 characters long. |
| C117 (u) | Get ID | Returns the primary ID string |
| C120 (u) S120 | Set prefix | Sets the prefix string. Syntax is the same as for Set ID. Beware that only 0..9, A..D, and # can be used. The prefix can be up to 4 characters long. |
| C121 (u) | Get prefix | Returns the prefix |
| C122 (u) S122 | Set location string | Sets the location string. Syntax is the same as for Set ID. The location strings can be up to 19 characters long. |
| C123 (u) | Get location | Returns the location string |

Complex Configuration Setup Commands

| Code | Operation | Comments |
|----------------------------------|--|--|
| C200 (u) | Set link map | Sets the link map which maps the logical port number to the physical port number. Syntax is *C200p0p1p2...D, where p0 is the physical port number (0..7) that will be recognized as port 0, p1 is the physical port number recognized as port 1, etc. Any ports not listed will be assigned in increasing order following the last one specified. If there is a local repeater port, the first one should be logical and physical port 0 – not absolutely required, some of the commands which treat the lower numbered physical port which is a local radio as the primary repeater port will may not send telemetry to the correct port if this is not done. |
| C201 (u) C202 C203 C204 | Set local radios Set link radios Set remote base radios Set irlp port | Sets the port types. Syntax is *C201r1r2...D, where r1r2... is a list of physical ports from 0 to 7. For example *C2010D sets the first port (physical port 0 as the only local repeater port), and *C2021234567D would set all of the other ports as link ports. Any conflicts between these commands are resolved as the command is entered, in favor of values specified in that command. The receive signal detect qualification and unqualification delays for each radio are set to the respective normal values for the radio type. The PL/COR |

| | | |
|----------|---------------------|---|
| | | required state is set to the defaults for the radio type. Be very careful in using these commands remotely. The change takes place immediately and a mistake can make it difficult to control the system. |
| C210 (u) | Define group | Sets a group membership. Syntax is *C210gr1r2r3D, where g is the group number (0..3), and r1, r2, ... are port numbers (linkmap applied) |
| C211 (u) | Define group linked | Sets the group members which are linked by default. Syntax is *C211gr1r2r3D, where g is the group number (0..3), and r1, r2, ... are port numbers (linkmap applied). You do not need to define the group members first. Radios included here which are not group members will be ignored, but will be remembered if they are included in the group later. |

Audio Amplitude and Deviation Calibration Commands

| | | |
|----------|-----------------------------|--|
| C219 (u) | Turn on test tone | Turns a 1 kHz tone on and off for test purposes. Syntax is *C219r, where r is the physical port of the radio (0..8, where 8 is the cpu card). |
| C220 (u) | Turn off test tone | Turns off the test tone from C219. Syntax is *C220r, as for C219. |
| C221 (u) | Set the test tone frequency | Sets the test tone frequency. Syntax is *C221ffffD, where ffff is the frequency in Hz. The value must be less than 4500 Hz. The default value is 1000 Hz, and is reset whenever the processor is reset. This value is not written to eeprom and is therefore not retained across resets. |
| C222 (u) | Set the test tone amplitude | Sets the test tone amplitude. Syntax is *C222aaaD, where aaa is the amplitude, from 0..255. The default value is 127, and is reset whenever the processor is reset. |
| C223 (u) | Set radio pot | Sets one radio pot value. Syntax is *C223rpv, where r is the radio (0..8, where 8 is the cpu card), p is the pot (0..3), and v is the value (0..255). See the schematics for pot function. The CPU telemetry pot is #3. The Radio receive, transmit, and telemetry pots are 2, 1, and 3, respectively. |
| C224 (u) | Set radio pot interactive | Sets the value of one pot, interactively. Syntax is *C224rp.....D, where r is the radio (0..8, where 8 is the cpu card), p is the pot (0..3), and Is a sequence of keystrokes to interactively set the pot value. 1 and 7 increment and decrement the pot value by 1. 2 sets the pot value to 255, 5 sets the |

| | | |
|----------|----------------------|--|
| | | pot value to 127, 8 sets the pot value to 0, 3 and 9 increment and decrement the pot values by 10, respectively. D saves the value, * escapes and returns the value to what it was before entering this command. |
| C298 (u) | Force transmitter on | Keys up a specific transmitter. Syntax is *C298n, where n is the physical port number. This will timeout after 5 minutes, even if it is not reset with C299. |
| C299 | Cancel 298 | Turns off force transmitter on. Syntax is *C299. |

Miscellaneous

| | | |
|----------|------------------|--|
| C225 (u) | Set teltolocal=0 | Command telemetry goes only to source. Responsiveness to RS232 serial port commands is much faster if CW telemetry is turned off while entering commands from the serial port. This command should normally be invoked before configuration via the serial port for that reason. |
| C226 (u) | Set teltolocal=1 | Command telemetry goes to local (and source). This is the default. |

User Level Commands, normally invoked by macros

| | | |
|----------|----------------------|---|
| C300 (u) | Site normal | Sets PL on, remote normal, interface normal. No macro capability at this time. |
| C301 (u) | Link normal | Unlinks all local radios (disconnects the links from the remotes) |
| C302 (u) | Interface normal | Links the local radios to all linked radios in the group (inverse of C301) |
| C303 (u) | Remote normal | Currently implements an empty dummy function. |
| C310 (u) | Force ID | Set ID timer to 0 on all radios in current group, thereby forcing 1064 Hz ID on all. Default for the *808 macro. Cactus manual says 808 should only go to local radios. Palomar manual says it goes to all but doesn't key up the link transmitters unless they already are (same as this implementation) |
| C311 (u) | Force local ID | Same as C310, but forces only all the local radios in the current group. |
| C312 (u) | Send ID | Sends ID as status: 800 Hz CW. Currently goes only back to command source radio. This includes the primary local radio if teltolocal=1 (the default) If used as the *809 command, the Cactus manual says it should go everywhere. |
| C313 (u) | Send location string | OK |
| C320 (u) | 440 off | Inverse of C321. Disables 440 repeat. |
| C321 (u) | 440 on | Enables repeat (loopback) on the local from which the command comes, or the lowest logical radio in |

| | | |
|----------|---|---|
| | | the same group as the source if it is a link, Connects the link if it was linked before. |
| C330 (u) | Link off | Unlinks radios in current group. |
| C331 (u) | Link on | Links specific radio to all other linked radios in group. Link is mapped to radio number by linkmap. |
| C332 (u) | Send link status | OK. |
| C334 (u) | Link delay off | Sets link delay off for link radios in current group. |
| C335 (u) | Link delay on | Sets link delay on for link radios in current group. |
| C340 (u) | Remote monitors off | Turns off remote monitor for the command source, with exception given above for remote monitor on. If the local port is in remmonl mode, then all remmonl ports in the group will have remmon cleared. If it is in remmon mode, remmon will be turned off for only that port. |
| C341 (u) | Remote monitors on | Turns on remote monitor for the command source port, if that is a local (repeater). Otherwise, turn remote monitor on for the lowest numbered logical port local in the group of which the source port is a member. If the command comes from the serial port, set remote monitor on for the lowest numbered local logical port in group 0. |
| C342 (u) | Remote monitor on with local link enabled | Turns on remote monitor for all of the currently linked local (repeater) ports in the same group as the command source. The local repeater ports remain fully linked to each other. |
| C344 (u) | Remote monitor off, port specified | Turns off remote monitor as if the command came from the specified port. Syntax is *C344n, where n is the logical port number |
| C345 (u) | Remote monitor on, port specified | Turns on remote monitor as if the command came from the specified port. Syntax is *C345n, where n is the logical port number. |
| C346 (u) | Remote monitor on with local link enabled, port specified | Turns on remote monitor with local link enabled as if the command source came from the specified port. Syntax is *C346n, where n is the logical port number. |
| C350 (u) | COR mode | COR only required for local repeater (all locals in group). |
| C351 (u) | PL mode | PL required for local repeater (all locals in group). |
| C352 (u) | Send PL status | Uses status of first local in group. |
| C354 (u) | COR mode for link | Set COR only for link. This is not sticky, it will be reset on site normal or processor reset. It is a protected command (link map is applied) |
| C355 (u) | PL mode for link | Set PL required for link. This is not sticky, it will be reset on site normal or processor reset. It is a protected command (link map is applied) |

| | | |
|----------|-------------------------|--|
| C356 (u) | Send PL status for link | Returns PL status for specific radio (link map is applied) |
| C357 (u) | Save PL mode for link | Save the PL/COR mode for link. Syntax is C357n, when n is the port number (link map is applied). |

Overall Structure

All primary repeater control functions are executed by the processor on the CPU board. The processor on the Radio Control Board handles initialization of radio board hardware, such as gain control pots, and generation of radio specific tones (key up telemetry, CW ID, busy signal).

The software for the CPU board is compiled into a program with a name format of SRSCnnmms. The main version number is nn. The minor version number is mm. During development of any minor version, different passes of the code are given a letter, s. The current v0.96 beta code as of the date of this document is designated, SRSC0096b. The binary executable to be loaded into the CPU board processor is in the file srscnnmms.hex. The software for the Radio Control board follows a similar naming scheme, SRSRnnmms. The binary executable to be loaded into the Radio Control board processor is in the file srsrnnmms.hex.

The controller has many parameters defining its configuration and operating behavior. Most of these can be easily changed by the site manager. These parameters have hard coded default values which are chosen so that most of the parameter values will be satisfactory for site operation without any further configuration.

The CPU and Radio Control boards have several forms of memory. Flash ROM on the processor chip contains the executable program. The size of this memory is 128kB, 64kB, and 32kB for the 18F8722, 18F4620, and 18F452 processors, respectively. Data RAM on the processor chip is used for working variables, program stack, etc. The size of this memory is 3982B for the 18F8722 and 18F4620, and 1536B for the 18F452. There is a non-volatile data EEPROM on the processor chip, which, in v0.96 of the program, is only used in the CPU board processor, to store a count and cause of any processor resets. It is 1kB on the 18F8722 and 18F4620. Finally, there is an external serial EEPROM on the CPU board which is used to store configuration parameters. The size of this memory is 64kB, and the board has provisions for adding a second chip to double the memory.

The hardware supports changing the contents of all of these forms of memory under program control. The beta software version, v0.96, does not support modification of program ROM (with the exception of the table which translates command names to macro numbers) – an external programmer is required to do this. It is intended that this capability will be added with , or shortly after, the release of software version v1.00.

Memory usage for the CPU board is as follows:

| | |
|--------------------|--|
| Program ROM | Executable code Library of sound sequences Command table Macro name command table |
|--------------------|--|

| | |
|----------------------------|--|
| On-chip data EEPROM | Reset counters |
| On-chip RAM | Working values of configuration parameters Program working variables, stack, etc. |
| Serial EEPROM | Stored values of configuration parameters Stored values of unlock codes Stored and working table of macros Scratchpad used to modify macro name command table |

In the Radio Control Boards, executable code and the library of sound sequences are stored in program ROM, as for the CPU board. Other parameters, such as digital pots settings, tone definitions and amplitudes, and ID frequency, speed, and amplitude are downloaded from the CPU board when the system is reset. Most of the parameter set functions change the CPU board stored values, but do not download the values to the Radio Control cards (digital pot setting is an exception, as it must be interactive). Therefore, if the ID is changed, the system must be reset for it to be effective. This behavior may be changed in a later version.

There is space in the serial EEPROM for storing the working copy and two backups of the configuration parameters, unlock code table, and macro table. The parameter backup and restore commands are used to copy the data from one of these copies to the other.

Configuring the System

Parameter Storage

Most parameters defining operation of the controller are represented by global variables of the CPU board program. They are stored in a serial EEPROM from which they are loaded on booting the program. The EEPROM contains three copies of the controller configuration parameters, designated working copy, backup, and deep backup. The working copy is generally synchronized with the RAM copy of the parameters. Some parameters can be set with an individual command to the CPU board via the RS232 serial port or DTMF received by one of the radios. These commands check parameters and most set both the RAM and EEPROM working value. Other parameters are set by writing directly to the corresponding address in the serial EEPROM. The working copy can be copied to and from the backup copy, the backup copy can be copied to the deep backup copy and the deep backup copy can be copied to the working copy, via DTMF commands. Macros are stored only in the serial EEPROM, and not in microprocessor RAM, except as they are being executed.

The commands for changing some specific parameters do input range checking and change both RAM and eeprom, so the effect of the command may be determined immediately. Specific commands are not provided for changing many of the configuration parameters. There are commands to change the value of any address in EEPROM directly. This should not normally be invoked manually from DTMF, as a mistake can corrupt the EEPROM. When used over RS232 from a controlling program on an attached PC, these commands provide a mechanism for efficiently configuring all parameters of the system.

Some parameters are stored differently.

1. The command translation table, which translates a sequence of DTMF characters into a word length internal command, is stored in program ROM. Because the PIC processor is capable of reprogramming itself, this table will be able to be customized in the field. There are two such tables in the system. One contains all of the built-in, published command names. The other contains the names used to execute macros. The macro name command table can be changed in the field.
2. Macro strings (the actual macros that are executed when a macro names is entered via DTMF or the serial port) are stored in the serial eeprom. They are included in the backups.
3. A tone sequence library is stored in program ROM. Pointers to the tone sequence library for particular telemetry sequences are stored in RAM and serial eeprom.

Initialization

Default configuration parameter values are built into the CPU board program. The first time that the program is started after it is written to the processor chip ROM, it will load the default parameters into the serial EEPROM and into RAM. On subsequent resets of the system, the processor checks for a configuration valid byte in the EEPROM, and if it is correct, the configuration parameters are loaded from the serial EEPROM. A reset is caused by power cycling, hitting the reset button on the CPU board, by issuing the C000 command, or by the watchdog timer built into the processor detecting a program hang-up. A reload of the hard coded defaults can be forced on the next reset by resetting the EEPROM configuration valid byte. There is a command, C100, to do this.

The default parameter load takes about 12 seconds. A beep-beep-beep confirmation is sent to port 0 when this is complete. If power is interrupted during the default load, it will start over again on the next reset. Subsequent resets take less than one second.

Any new program load will overwrite the configuration parameter working copy in serial EEPROM. If the program revision is a minor one with no changes to the EEPROM parameter memory layout, then previously configured parameters can be restored by using the restore command. For more significant program upgrades, this will not work. Therefore, a site manager should keep a record of changes made to the default configuration so that they can be quickly restored.

Basic Configuration

The default configuration is described in Appendix 1 of this document. It configures any system of 1 to 8 ports with the first port (physical port 0) defined as a local/repeater, and all of the other ports as links. If this is satisfactory for your site, only a few things are required to get started.

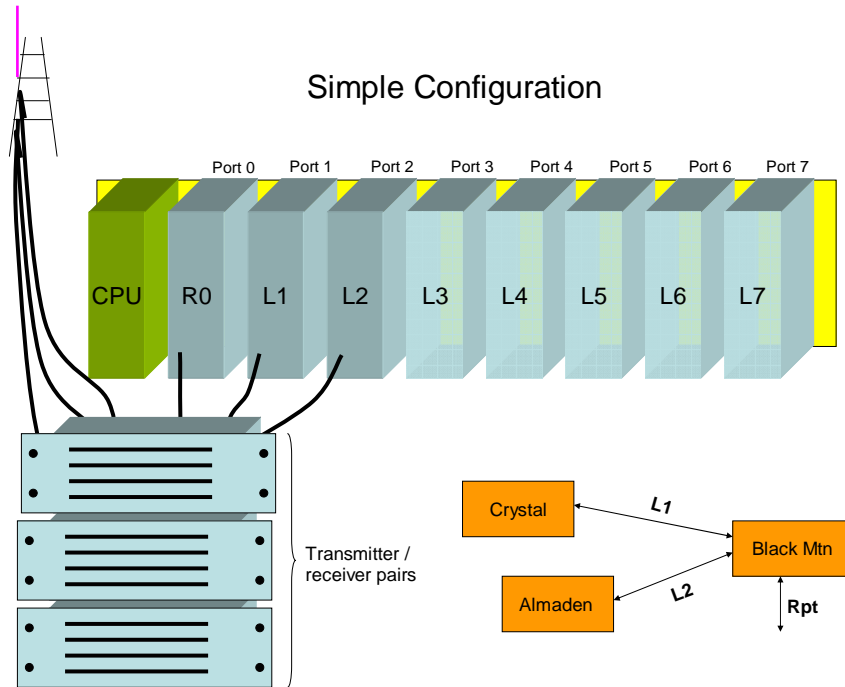

Unlock Code Definition

The initial program default defines only one unlock code, and that is the super-unlock code in unlock code number 0. The default code is 138065. The first thing that should be done to configure the system is to change the default unlock code and create some new ones.

There are two ways to set unlock code 0. The first is to use the command, C115. This command will not execute unless the current unlock code 0 is entered first, so to set it to a new value of 198767, the following could be entered by either DTMF transmitted to a receiver attached to Port 0 or by the serial port:

```
*138065
*C115198767D
```

If a computer is attached to the serial port on the CPU card, the *'s are not necessary. The D is not required in either case, as long as the unlock code is the maximum of 6 digits long. For the serial port, the D can be replaced by a carriage return. These details are described in the command list document. The command processor is not case sensitive, so either c115 or C115 will work.

The second way to set unlock code 0 does not require any knowledge of the current code., but can only be accomplished if you are physically at the controller. Pull all Radio Control boards from the card cage, attach a computer to the serial port, and use the C114 command:

```
C114198767<CR>
```

It is recommended that the unlock codes be 6 digits long. The controller cannot distinguish between an unlock code and any other command except by the characters

entered. The command processor does not use a command terminator character to separate one command from another. Therefore, no command or unlock code can be a prefix substring for any other command or unlock code. None of the commands in the default command table or default macro name table begin with 1, so unlock codes beginning with 1 are safe to use. When modifying the macro name command table, it is possible for the site administrator to create commands with any name, so caution must be exercised to avoid conflicts between commands or unlock codes.

Next, set unlock code 1, which is also a super-unlock code, and at least one additional unlock code, which will not be a super-unlock code. The command to set an unlock code is C110, and it will not execute unless a super-unlock code is entered first. This command places codes into the unlock code table in the lowest numbered available slot in the unlock code table. Since there is no unlock code in slot 1 at this point the next code will go there, and define the second super-unlock code. So, to define the second super-unlock code as 176545, and the unlock code number 2 as 123456, enter the following:

```
*198767
*C110176545D
*C110123456D
```

After this, don't use 198767 (unlock code 0) any more. It is only needed to change itself. Because anyone with a receiver and a DTMF decoder can tell what you are doing over the air, it is good practice to minimize use of the super unlock codes, particularly unlock code 0.

Note that once you enter an unlock code, you don't need to reenter it before every command that requires one. The system will remember that you entered an unlock code for 5 minutes, and that 5 minute timer gets reset every time you enter a new command. If a command comes in from a different port from which the unlock code is first entered, the unlocked state is reset and the code will need to be reentered. The site normal and remote normal commands also reset the unlock state.

ID and Location Configuration

The call sign ID should be set next. This is easy from the serial port, and slightly cumbersome from DTMF. To set it from the serial port, use the S116 command. When the controller turns on the transmitter just to send an ID, it starts the CW at the same time as it pulls down the PTT line to the transmitter. Most transmitters take some time to come up, so this can clip the leading dit or dah of CW unless a space character or two is inserted at the beginning of the ID. A space character at the end is also recommended. So, to set the ID to " kj6k ", you would enter:

```
S116  kj6k <CR>
```

The CW generator is not case sensitive. Either kj6k or KJ6K will work.

From DTMF, a two key sequence is used to define each character in the ID, using the C116 command. A table defining the sequence for each character is included in the command list document. The same ID is entered with:

```
*C11601015251605201D
```

It is nice to define a sequence of characters describing the location. This can be returned with the C313 command (or with a macro which calls this command). This is done in the same way as for the ID, with the S122 and C122 commands. To set it to "BLK" use one of these two sequences:

```
S122blk<CR>  
*C122225352D
```

Prefix Configuration

When controlling from a link radio, the command is not prefixed with *, but with a prefix code. This is necessary so that this controller can tell that the command sequence is destined for it and not for some other controller down the chain of links. The default prefix is "00". The appropriate prefix must be coordinated with the other site managers in the system of linked repeaters, otherwise nothing works. To define the site prefix, use the S120 or C120 commands in the same manner as for setting ID, above. To define the prefix as "98", enter either one of these two sequences:

```
S12098<CR>  
C1209080D
```

The prefix can be up to 4 characters long. Any DTMF character can be used within the prefix except *. To use the prefix, it must be preceded with a # character - this tells the controller to start looking for a prefix.

Level Adjustment

Levels for the audio and telemetry should be set next. There are many ways that this can be accomplished. The procedure here is recommended to make sure internal levels within the controller are within the dynamic range of the circuits, and allows the default relative telemetry tone and CW levels to give the desired result.

This procedure requires a calibrated signal generator to produce a signal with 1kHz tone modulation of known deviation, and a calibrated deviation meter. If this equipment is not available, please contact Sierra Radio Systems for an alternative adjustment procedure.

This procedure will properly adjust for most component and radio gain variations. Any small channel to channel gain variations in the audio mixers on each Radio Control boards cannot be compensated for. The resistors used in the mixer are 1% resistors and the switches have very low on resistance compared to the circuit impedance, so this variation should be negligible.

All except the first step of this procedure can be accomplished remotely. The level in the first step is not critical, so if necessary, the default pot value can be used.

Set the CPU telemetry pot and backplane level

The nominal voltage for full deviation audio (most often 5 kHz) on the backplane audio bus is 1 Vp-p.

Telemetry tones generated by the processors on the CPU and Radio Control boards can have digitally defined levels of from 0 to 255. The scale is linear, with 0 giving no output. The 4 possible simultaneous tones are generated with two tones generated at each of

two PWM ports on the processors. The peak sum amplitude from either of the two generators on one port must not exceed 255, so the normal maximum single tone amplitude is 127. DTMF tones defined with an amplitude of 127 will be generated with each tone having an amplitude of 127, and the peak of the dual tone at 254. Therefore, we define the nominal peak deviation to be generated with a tone amplitude of 255 from the tone generators.

Turn on the CPU board test tone generator. It defaults to 1kHz at an amplitude of 127.

*C2208

Adjust the CPU board telemetry pot to produce a 1kHz tone amplitude on the cpu telemetry line on the backplane of 0.5 Vp-p. Either command C223 or C224 can be used to do this. See the command list documentation for details. The pot setting should be close to NNN.

*C22383nnnD

Adjust the transmitter level pots

Leave the test tone on. Next adjust the transmitter level pots on each of the Radio Control boards to produce a ½ full deviation level (2.5 kHz).

*C223r1nnnD

Adjust the receive level pots

Turn off the test tone (*C2208). For each port, do the following. Use a service monitor or other calibrated source to deliver a full deviation 1 kHz test tone to the port's receiver. Adjust the receiver gain pot on the Radio Control board to produce a full deviation output from the any of the previously calibrated transmitters. To be consistent, it is probably best to use the port 0 transmitter for all of these operations.

*C223r2nnnD

Modified transmit and receive level adjustment for increase link dynamic range

Links can carry mixed audio from multiple sites. In addition, the link signal to noise should be high compared to typical mobile or handheld input to a repeater. Therefore the nominal link deviation can be set to a lower value allow for additional dynamic range. To do this, using the same procedure as above, set the link transmitter level pots to produce a lower deviation level at the link transmitter output (for example, ¼ full deviation), with the same calibration tone input. The link receiver input pot for any port calibrated in a similar manner at the far end of the link will need to be set to a correspondingly higher level so that the deviation at the transmitters is correct.

Adjust the Radio Control board tone generator pots

For each Radio Control board, turn on the transmitter and the test tone for that board with 1kHz and level 127. Adjust the tone generator level pot to deliver ½ full deviation (2.5 kHz) on that transmitter.

*C223r3nnnD

Individual telemetry tone sequences and CW levels are set digitally and will provide consistent, well defined, deviations following the above procedure. The default values

should be acceptable in most cases, so try them out before attempting to change the individual tone values. Please provide feedback to Sierra Radio Systems on the default tone levels after the digital pot calibration. Future version defaults will reflect the best compromise from that feedback.

Tone generator pre-emphasis

The controller CPU board and Radio Control board hardware do not do any pre-emphasis or de-emphasis in main audio paths or in the tone generator audio path. Most site configurations will interface to the radios without de-emphasis in the receivers or pre-emphasis in the transmitters. Therefore, the audio within the controller will be pre-emphasized, as it was first pre-emphasized in the transmitter that is the original source for the traffic (eg., a user's HT). The rest of this discussion assumes that pre-emphasized audio is being carried in the controller audio paths.

The audio feeding the 8870 dtmf decoder on the Radio Control boards is de-emphasized in the dtmf pre-filter provided on the board. The chip will accept twist (high tone to low tone amplitude difference) of up to 10 dB, so this should be acceptable even if previously de-emphasized dtmf is fed to the board.

The telemetry sequence generators on the CPU and Radio Control boards are optionally pre-emphasized directly in the software sound sequence generator. If the `preemp1g` configuration variable is set to 1 (the default), then pre-emphasis is applied to tone sequences. If it is set to 0, then pre-emphasis is not applied. This can be changed by directly modifying its value in the serial eeprom and resetting the controller.

The test tone (commands C219 - C222), CW generator, and command parameter prompt tone directly drive the tone generators, without using the tone sequence generator, so no pre-emphasis is applied. Pre-emphasis is applied (if the pre-emphasis flag is set) to all of the other telemetry tones, which are generated by the tone sequence generators. If no pre-emphasis is applied, the tone amplitude parameter will be directly proportional to deviation out of the fm transmitters, independent of the frequency of the tone. For a given tone amplitude parameter, the deviation for pre-emphasized tones and non-pre-emphasized tones will be the same at 1 kHz. The pre-emphasized tone amplitude is proportional to frequency for all frequencies below 2441 Hz. The amplitude is undefined above 2441 Hz, so those frequencies should not be used in tone sequences. The standard 750 us time constant is not respected, so tones below 212 Hz will have an excessively small deviation. The actual amplitude sent to the tone generator for a specific tone in a tone sequence is the product of the tone sequence amplitude and the frequency divided by 1 kHz. If this would result in an individual tone amplitude exceeding 255, then 255 is used. The sum of the amplitudes of the two tones in a dtmf tone must not exceed 255, or the tone generator will overflow, producing strange sounds. This is not checked in the controller software. Therefore, the maximum tone amplitude for any dtmf tone is given by the formula, $amp * (f1/1000 + f2/1000) \leq 255$. Maximum values for dtmf tones are given in the following table:

| dtmf char | low f (Hz) | high f (Hz) | max amp |
|------------------|-------------------|--------------------|----------------|
| 1 | 697 | 1209 | 133 |
| 2 | 697 | 1336 | 125 |

| dtmf char | low f (Hz) | high f (Hz) | max amp |
|-----------|------------|-------------|---------|
| 3 | 697 | 1477 | 117 |
| A | 697 | 1633 | 109 |
| 4 | 770 | 1209 | 128 |
| 5 | 770 | 1336 | 121 |
| 6 | 770 | 1477 | 113 |
| B | 770 | 1633 | 106 |
| 7 | 852 | 1209 | 123 |
| 8 | 852 | 1336 | 116 |
| 9 | 852 | 1477 | 109 |
| C | 852 | 1633 | 102 |
| * | 941 | 1209 | 118 |
| 0 | 941 | 1336 | 111 |
| # | 941 | 1477 | 105 |
| D | 941 | 1633 | 99 |
| Dial tone | 350 | 440 | 255 |
| Busy tone | 480 | 620 | 231 |

Remember that there will often be more than just a dual tone being transmitted at once. It can be overlaid with an additional tone, or some audio at the same time. To prevent overdeviation, the amplitude of a given dual tone should be kept below the 255 maximum, if the system is calibrated for that to be at the maximum system deviation. Also, a dual tone of a given amplitude will sound twice as loud as a single tone of the same amplitude, and will have twice the peak amplitude. Finally, pre-emphasized dual tones of the same amplitude setting will have the roughly the same audible volume level (without adjusting for the frequency dependence of human hearing).

Given the above, recommended amplitudes for most single tone key up and command telemetry sequences are 127 (1/2 full deviation), most dual tone telemetry (dial tone and busy tone, for example) are 85 (same audible amplitude).

Complex Site Configuration

Differences between port types

The table below describes the differences in behavior between ports configured as repeaters, links, irlp nodes, and remote bases. Some of these are just the default behavior that is created when the port type is defined, and can be changed, either by port type or by individual port. Others (such as ability to accept commands) are built into the programmed behavior of the port type. See the SRS Controller Software Configuration spreadsheet for a detailed description of all of the parameters which can be changed.

| | Repeater/ local | Link | VOIP link | IRLP | Remote base |
|-----------------------------|--------------------|------|--------------|------|----------------|
| Retransmits input on output | x | | | | |

| | Repeater/ local | Link | VOIP link | IRLP | Remote base |
|---|-----------------------|--------------------------------------|-----------------|--------|----------------|
| Accepts commands preceded by * | x | | | | |
| Accepts commands preceded by #prefix | | x | x | | |
| Transmits ID | “polite” algorithm | “link ID 2” algorithm | | | |
| Default CW ID frequency (Hz) | 1064 | 1064 | | | |
| Default CW ID speed (WPM) | 20 | 24 | | | |
| Default ID level (0..255) | 80 | 40 | | | |
| Default transmit carrier off delay (s) | 4.0 | 4.0 0.1 with link delay off | Same as link | 0.1 | 0.1 |
| Default COR/PL recognition delay (ms) | 50 | 50 | 0 | 0 | 50 |
| Default COR/PL drop recognition delay (ms) | 150 | 5 | 0 | 0 | 150 |
| Default PL status | PL on | PL on | PL off | PL off | PL off |

Link map

The physical location of a Radio Control board in the card cage determines the address which the controller’s software uses to direct communicate with the card. In most cases, the site should be set up so that this address corresponds to the identity by which users of the system will control a particular port. In the simple configuration setup described earlier in this document, the repeater is connected to the Radio Control board in the first slot to the right of the CPU board. The program thinks of this as port 0, and any commands directed to change something on a specific port would use 0 as the parameter to direct the command to the repeater port. The Radio Control board to the immediate right of the repeater port, is port 1. Link on/off commands would control that port by using the parameter of 1. So from left to right, the repeater is attached to the first Radio Control board, and is referred to as port 0. Link 1 is attached to the second Radio Control board, Link 2 is attached to the third Radio Control board, etc.

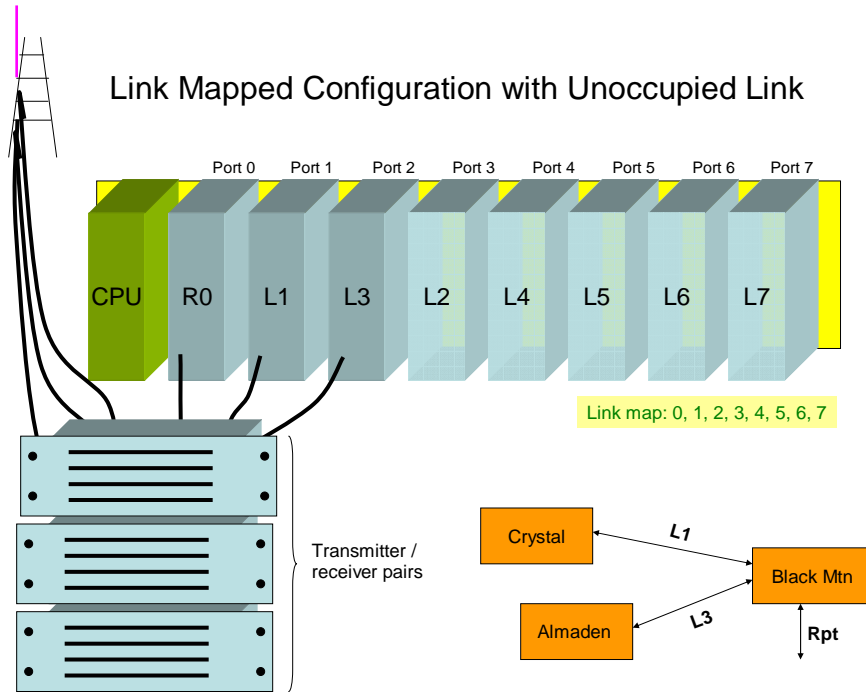

There will be situations in which the physical address of a Radio Control board (which is also defined by its physical position in the card cage), cannot be same as the identity that a user will want to refer to it. For example, a site may be starting out with a three port controller, with 1 repeater and 2 links. The eventual goal may be to grow this site to 4 links. In that case, it would be desirable to define which link will be link1, 2, 3, and 4 when the site is first set up, so that the designations will not change when new ports are added. If the first 2 installed links are not Link 1 and Link 2, then you need to define a link map to translate Link 1 and Link 2 to the physical port address where the links are attached. If there is at least one repeater at the site, one of them should be attached to port 0. The reason for this is that during command entry from the RS232 serial port, CW telemetry is also directed to port 0.

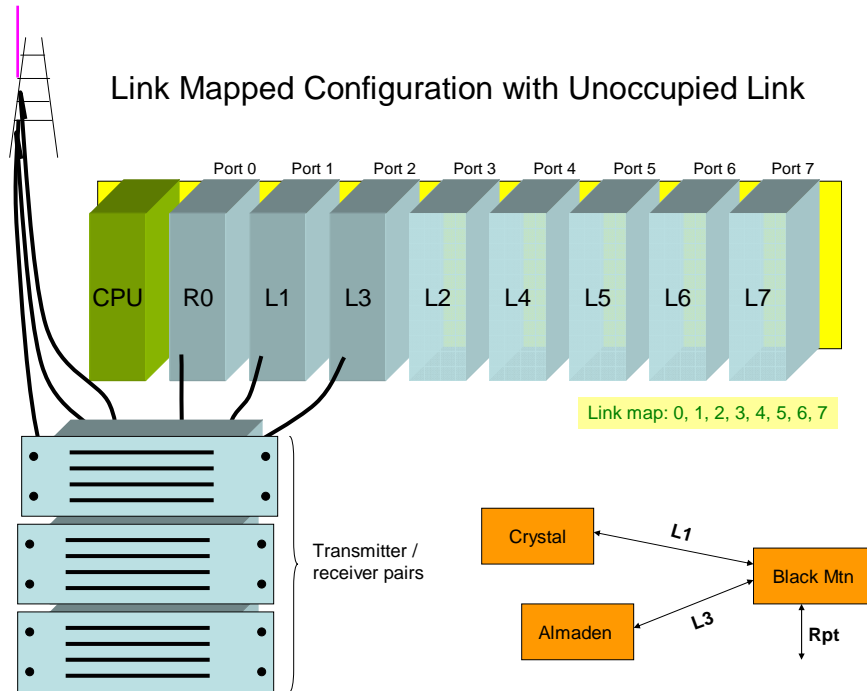

The link map describes a mapping between the logical designation for a port, and the physical location of that port in the controller card cage. The first element of the link map is the physical port for logical port 0, the second is the physical port for logical port 1, etc. So if the repeater is connected to the Radio Control board in the first slot (port 0), Link 1 is connected to the board in the second slot, Link 2 to the third slot, etc., then the link map will be 0,1,2,3,4,5,6,7. This is the default. If you start with a three port system consisting of a repeater, and links 1 and 3, with the intent of later adding link 2, then you would attach the repeater to port 0, link 1 to port 1, and link 3 to port 2. Then, you should define the link map as 0,1,2,3. Later, when you add link 2, you can put it in the 4th slot (port 3) and no additional configuration is required.

Multiple Repeater Complex Configuration

The controller is capable of managing multiple, semi-independent repeater systems. To do this, the ports for each system are grouped into a separate "group." A controller can be configured with a maximum of 4 groups, numbered 0..3. Group 3 is used for temporary, dynamic reconfiguration of the groups via the Create Linked Group (C212) and Restore Groups (C213) commands, so only groups 0..2 should be used for the site configuration.

To provide a level of command isolation between groups, most commands apply only to the ports that are in the same group as the port from which the command originates (commands from the serial port apply to group 0). There is a separate command which can be used to explicitly change the group to which commands apply, so that any command can be applied from any port.

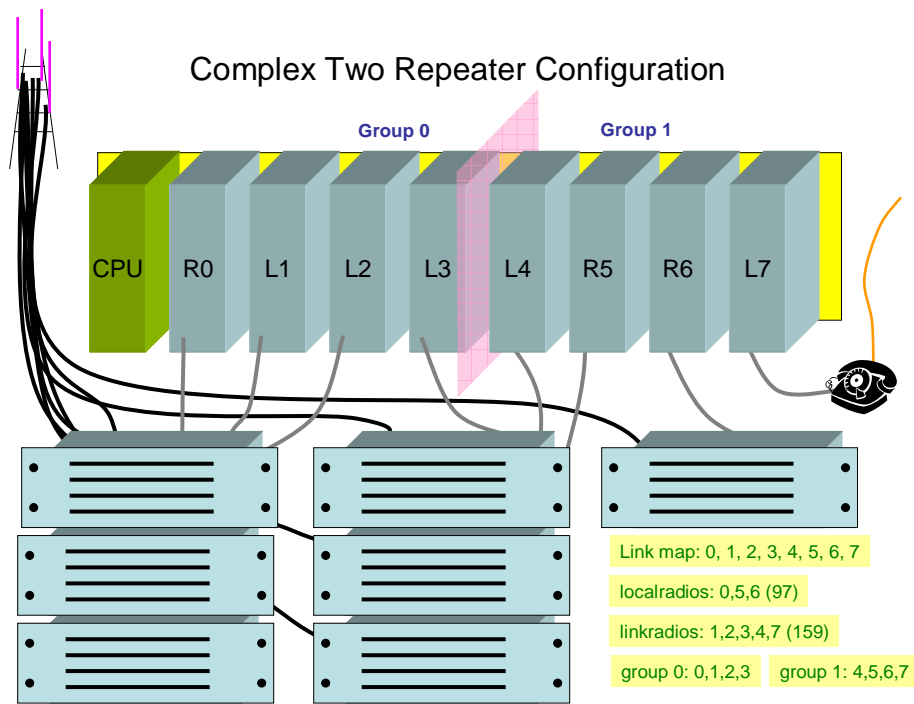

Complex Two Repeater Configuration

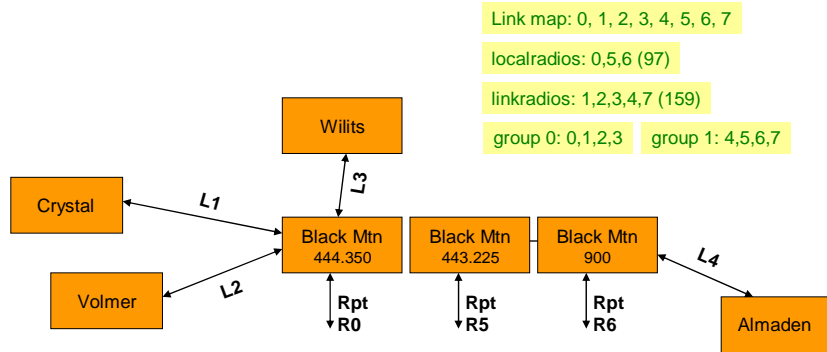

Detailed Tone and Tone Level Control

The amplitude of individual telemetry tones and CW can be adjusted after calibration by setting the digital amplitude used by the tone generator. There are no specific commands to make these changes; the parameters must be changed by directly modifying the parameter value where it is stored in the serial eeprom. The addressed for all of the controller configuration parameters are listed in the SRS Controller Software Configuration spreadsheet.

As an example, let's change the amplitude of the CW ID for link ports. The default value is 40. If the pot calibration procedure described above has been used, with a system peak deviation of 5 kHz, then this tone will have a deviation of approximately $40/255*5 \text{ kHz} = 784 \text{ Hz}$. If this is still objectionably loud, which may be the case if there is no 1064 Hz notching at the link receivers, then you might want to readjust this to something like 500 Hz. To do that, the value should be $255*500/5000 = 25$. The software configuration spreadsheet shows that the eeprom address for the link ID CW amplitude is 192 (version 0.90e software). To read the current value, use the read eeprom byte command, defined in the SRS Command List document as C107. After entering an unlock code, you can verify the current value with *C107192D. This will return 40, if the value has not been previously changed from the default. To change it to 25, use the set eeprom byte command (C106):

```
*C106192B25D
```

The processor will then need to be reset (C000) for the new value to be downloaded to the Radio Control cards where the ID's are generated.

Telemetry tone sequence amplitudes are slightly more complicated to adjust. To change the "beep-boop" telemetry provided upon key up on a repeater port when there are links active and link delay is on, the "lnkintsnd" parameter needs to be changed. There are two forms of this parameter in the eeprom, a global default, which is used to simultaneously set the values for all of the ports, and individual values for each port. Within the lnkintsnd parameter, there is a 16 bit integer which is an index into a table of sound sequences, and an 8 bit integer, which set the tone amplitude. To change the amplitude for all ports, use the C106 command to set the amplitude part of the lnkintsnd parameter (address 221 + 2), and reset the processor to load it into RAM, then issue the set rlnkintsnd command to transfer this value to all of the individual radio specific values, in rlnkintsnd. To set this amplitude (default is 127) to 80, the command sequence is:

```
*C106223B80D
*C000
*C231
```

Unfortunately, this is a somewhat complicated set of steps, which will be simplified in a future version of the software. In addition, a program running under Windows will be provided to do this programming automatically via the serial port.

Controller Timing Parameters

There are many parameters which determine the timing and delays of various operations within the controller. Most of these are described in the SRS Controller Software Configuration spreadsheet. These parameters are set by writing directly to the corresponding addresses in the serial EEPROM and then resetting the processor to make the new value active.

Transmitter on and off timing

The detailed timing involved in turning the transmitters on and off are shown in the receive qualification, squelch and transmit timing appendix. It is determined by two basic variables. Turn on is adjusted by rcvqdelay, which should normally be short, but

can be lengthened to reduce the triggering of the transmitter on noise (particularly important if PL is off) or from unidentified operator kerchunking. Turn off is adjusted by two rcvunqdelay and the transmit timeout variables. Each of these has several variants depending on the type of port (repeater, link, etc.).

ID timing

Timing of identification also uses several parameters, and is different for repeaters than for link transmitters. See the ID section of this document for a detailed description of the ID algorithms and adjustment parameters

Controller Behavior Parameters

There are many other parameters to adjust the behavior of the controller. Many are switches to select between a couple of different choices on a particular behavior. See the SRS Software Configuration spreadsheet for details.

Macros

A macro is a list of built-in commands or other macros that will be executed as if it is a single command. The commands that are made available for most users of a system are implemented as macros. There is space available in the serial EEPROM for storing 400 macros. Macros are executed by entering commands which are specifically defined to call specific macros.

Defining Macros

To define a macro, just enter the sequence of characters you would use to execute the same commands from DTMF or the serial port into the macro string. This is done with the set macro commands, C130 or S130.

As an example, if you want command 003 to turn link 1 PL off, then the command C3551 should be assigned to the macro which is called by the 003 command. Referring to the command reference or Commands/Macros section, above, this command execute macro number 3. Using the S130 command from the serial port, define the macro as follows:

```
S130 3 C3551<CR>
```

From DTMF, the command is:

```
C13030012330505010D
```

You can check that this worked correctly by using the get macro command, C131:

```
C1313D
```

An unlock code must be entered prior to using these commands. You should also verify that it works by executing the macro command:

```
003
```

User Entered Parameters in Macros

Some commands take parameters to define what the commands do. When there are only a small number of valid parameter values, user level commands are best implemented by creating a macro for each of the possible command parameter values.

For example, the command to turn on a specific link port, C331 takes a single digit parameter to define which link is to be turned on. To turn on link 2, you would enter C3312. The command parameter prompt tone will come on when C331 is entered and turn off when the subsequent 2 is entered. For most installations, macros should be created specifically for each port. For example, a macro 012 could be defined to turn on link 2, and a separate macro for turning on link 3.

Commands to set a remote base frequency may need to allow a wide variety of possible parameters, so that creating a macro for each value is not feasible. In this case, if the command is to be called from a macro, there needs to be a mechanism for pulling dtmf characters from outside the macro itself. This is done by inserting the % character in the macro where the parameter is to be inserted. For example, if the macro called by the 012 command is set to C331%, the entering 012 will cause the prompt tone to come on and the link port number can then be entered. A subsequent command could also be included after this command within the same macro. There is no mechanism, however, for storing the entered parameter and using it in multiple commands within one macro. The % and subsequent parameter entry would need to be used for each command in the macro.

Setting Macro Execution Permissions

You should also set the macro permission to define the conditions under which the macro will execute. This is an 8 bit mask, entered as a decimal number, with bits defined as follows:

| | |
|------------|--|
| 1 | Block the command if COR and a required PL is not detected |
| 2 | Block the command if the port from which the command is being entered is not currently linked |
| 4 | Block the command if no local radio (repeater) is currently linked - if you want to be able to always hear if someone is controlling the machine while monitoring from the local repeater, this should be set. |
| 8 | Block the command unless an unlock code has been entered |
| 16 | Block the command unless a super unlock code has been entered (note, that macros can be changed with an unlock code, so this is not effective security, unless the base command being called by the macro requires a super unlock code). |
| 128 | Allow the command to be executed if there is explicit code in the command to allow it when other conditions are not met. This is used primarily for link on commands directed at the same port from which the command is coming - it should be allowed even if link is off for that port and link on for other ports would be blocked. |

To set the permission to block the macro defined in the previous example if the command source port is not linked or the local repeater is not linked, set the macro permission to 2+4=6, with the command sequence:

C1323B6D

ID

Automatic identification by morse code is provided for repeater and link ports.

The repeater ports use a “polite ID” algorithm for determining when to send the ID. There are a number of parameters which can be used to configure that behavior of this algorithm. The polite ID is designed to minimize the occurrences of an ID being sent on top of an ongoing conversation, while strictly conforming to the FCC identification regulations for the amateur service. If the transmitter comes on after a long period of inactivity, then the ID will wait until either the transmitter is unkeyed, or a moderate delay elapses. This delay is configurable as the `id_politeto` parameter, and defaults to 30 seconds. During an ongoing conversation, an ID will be sent on top of the conversation if the transmitter is on continuously for a maximum allowed period since the last ID. This period is configurable as the `id_absto` parameter, and defaults to 10 minutes. In order to minimize the chances of an ID being sent over an ongoing conversation, the ID will key up the transmitter and be sent during an idle period in the conversation (transmitter not keyed) when there is still some time left before the maximum allowed timeout period. This time remaining is configurable as the `id_idleto` parameter, and defaults to 2 minutes. If an ID was the last thing sent (transmitter not keyed up since the last id), then no more id’s will be sent.

In linked repeater systems in which most conversations take place with between people who are not on the same local repeater, this polite ID is not the best algorithm to minimize interference with an ongoing conversation. In that case, it is better to send the ID over the top of the local input, and miss sending it over someone coming in from the links. Thus the polite feature does the wrong thing. The best configuration in that case is to set the `id_politeto` parameter to zero, and the `id_idleto` parameter short (a few seconds). Keying up the transmitter to send a final ID can also be disabled by setting the `nokeyup4id` configuration parameter to 1. Once a repeater port ID starts, it will always complete, holding up the transmitter if required.

There are several options for the link id. The basic ground rule of these options is that an ID will not key up the transmitter or hold up the transmitter to complete an ID. This prevents ID’s from keying up multiple transmitters in a linked system when there is no immediate conversation taking place. Dropping transmit immediately after releasing PTT is important in cases where a simplex remote base is being controlled from a link. The interval between ID’s is set by the same `id_absto` parameter used for repeater port ID. If ID times out while the transmitter is active, the ID will be fired immediately. If ID times out while the transmitter is idle, ID will fire following a short delay after the transmitter next becomes active. This delay is set with the `id_lnkidleto` parameter. The ID will be truncated if PTT is released and any transmit hang delay completes before the ID completes. The ID timeout timer will not be reset in this case. The `linkidtype` parameter can be changed to force the timer to reset even if the ID is truncated.

Appendices

Appendix: MELabs EPIC Programmer Setting

The ME Labs EPIC programmer should be connected to the programming port on the card to be programmed. With the connectors on the EPIC and CPU or RCB cards in the correct orientation, the board and programmer will lay out neatly side-by-side as shown in the next figure. The figure shows an RCB card. The CPU connector is higher on the board, adjacent to the reset switch.

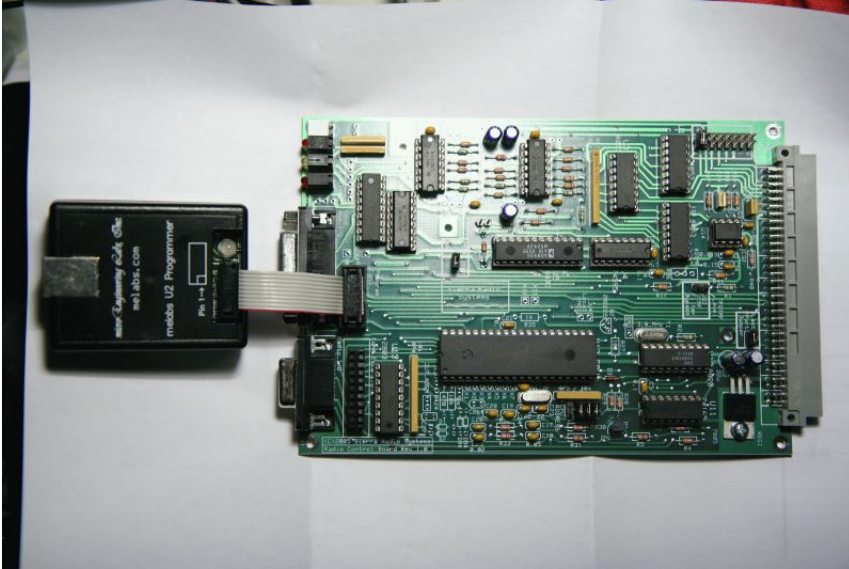

For programming, power must be applied to the card. This is most easily done with the card inserted in the controller card cage. When programming an RCB, the CPU card must be removed from the card cage.

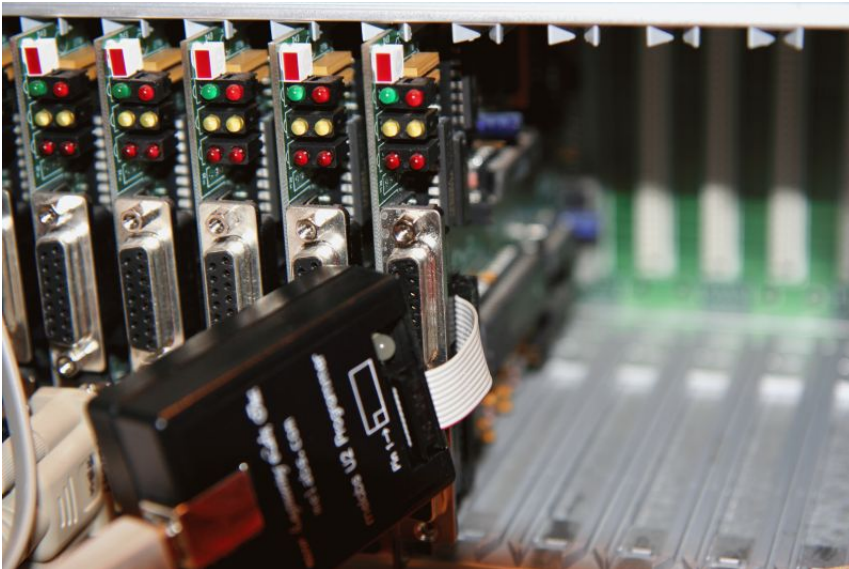

The programmer must be configured to program the correct type of processor, and settings in the Options menu need to be defined to tell the programmer to pull configuration data from the .hex file, to erase the part before programming, and to program both the on-chip data EEPROM, and the program ROM.

The EPIC software version should be v4.20, or later. For programming the Radio Control boards with v1.0 hardware, the programmer should be set up to program the 18F4620 processor. The Melabs programmer software screen will look like this:



After setting the Options menu correctly, it should look like this:

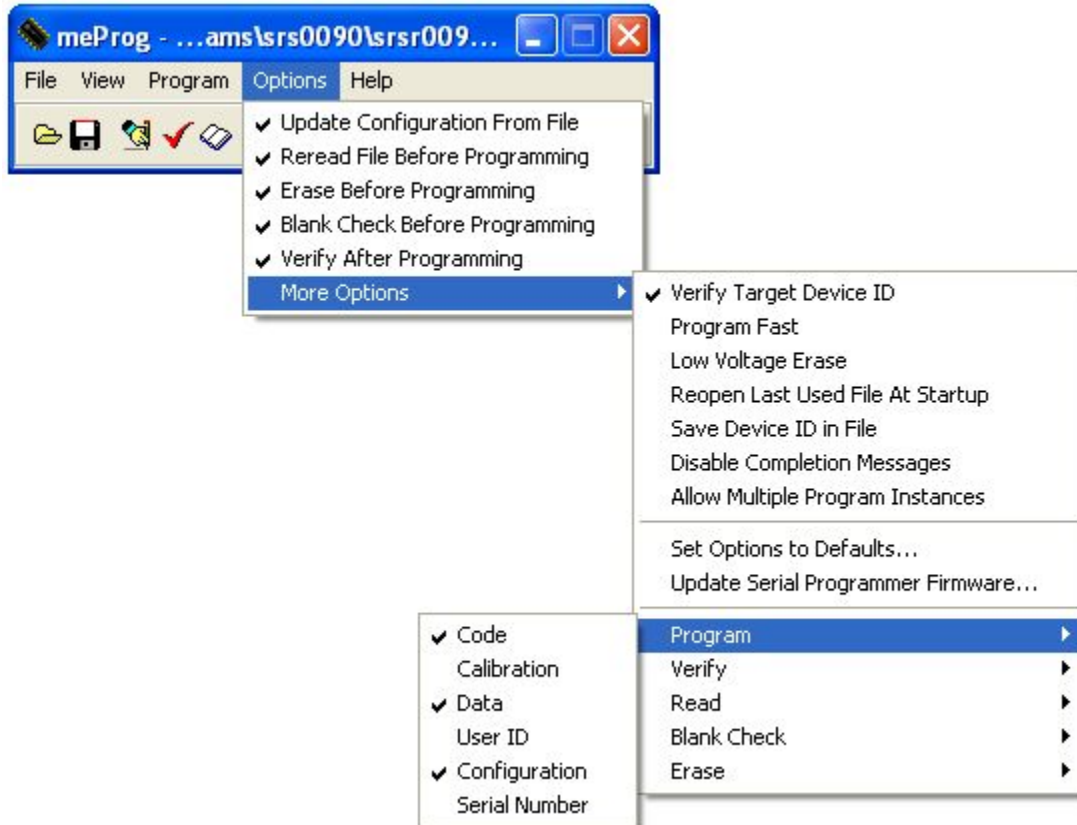

After opening the Radio Control board software .hex file using the File menu, the program will show the first few items of the processor configuration as follows:

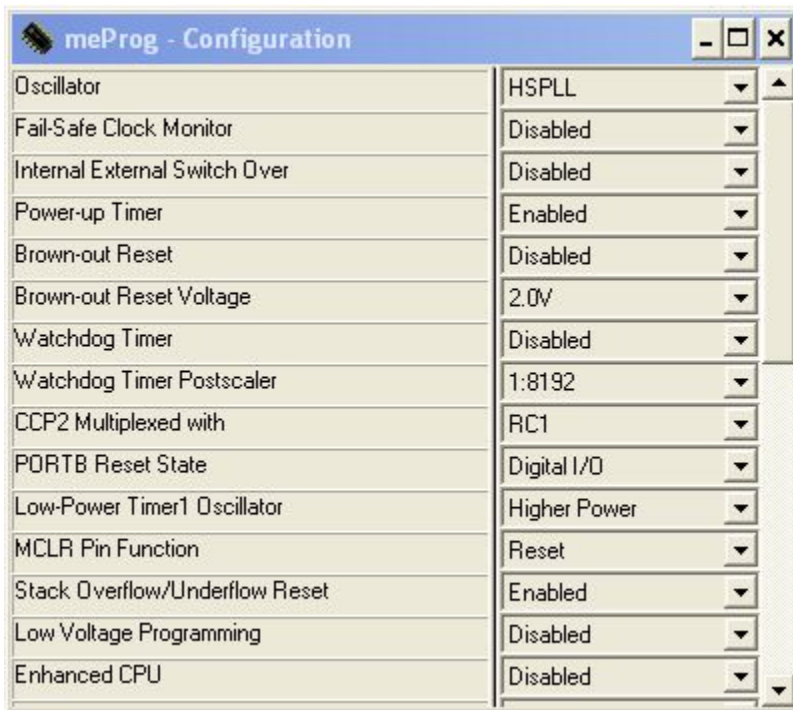

The CPU board must be pulled from the backplane while programming the Radio Control boards. This is because the CPU board can pull the the backplane reset line low to reset the CPU's on each of the Radio Control boards, thus interrupting the programming sequence for the Radio Control board. The Radio Control boards may be left in place while programming the CPU board.

To program the CPU board, the processor should be set to the 18F8722. The other options parameters should be set as for the Radio Control boards. After opening the program .hex file, the first items of the processor configuration should look like this:

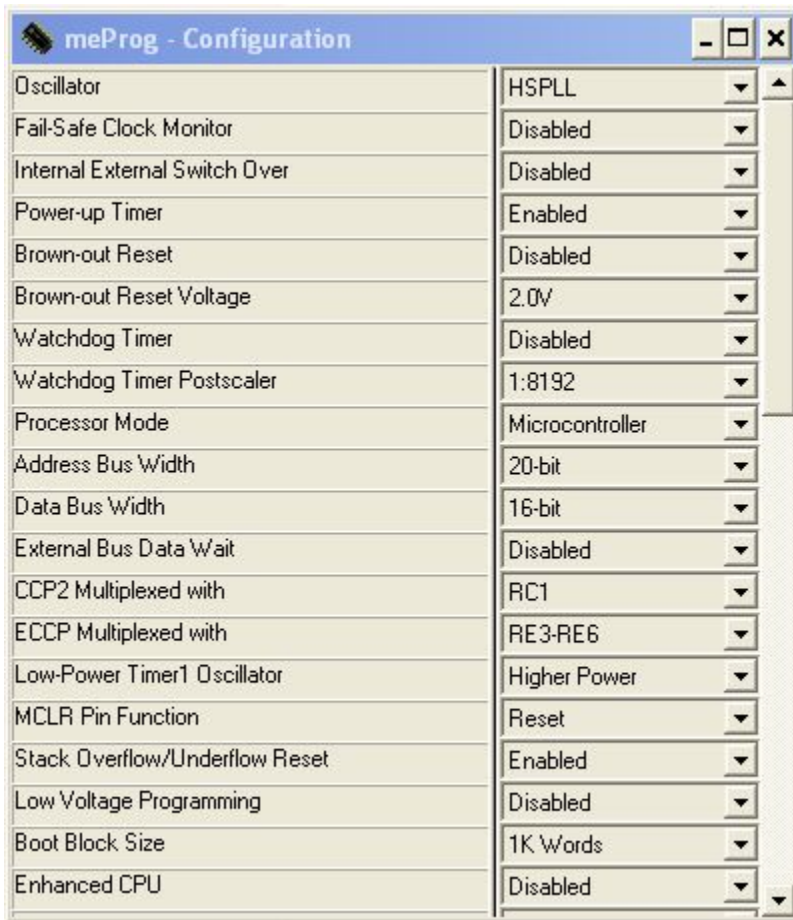

Appendix: Receive qualification, squelch and transmit timing

See the figure for a description of the timing of received signal detection, received signal squelch, and transmitter timing.

In most cases, the audio from the receiver is muted when no carrier is detected. In this case, the receiver muting via the audio switches is not critical in the controller. It's primary purpose is to avoid passing grunge or other audio which opens receiver squelch when PL is not detected. In that case, if the audio is not muted, and the transmitters are switched on due to either telemetry or input from another receiver, then the undesired audio would also be passed to the linked transmitters.

In other cases, the receiver and/or receiver interface provides COR and PL detect signals, but does not mute the receive audio. This means that the audio line from that receiver has a high level of broadband noise when there is no signal present. In this case, the switches in the controller radio card must provide the squelch function (even if only one receiver is on, the transmitter remains on for a few seconds after the incoming carrier is lost), and timing of the squelch operation is therefore critical to avoid passing high levels of audio noise.

Transmitter PTT Timing

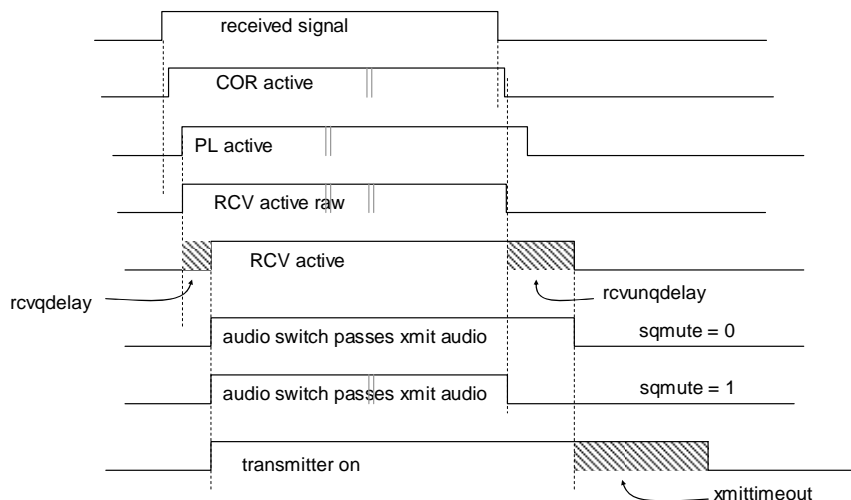

It is desirable for the controller to have some mechanism for dealing with transient false COR or PL detect signals, which could be due to either noise, or short “kerchunking” of the repeater. This is implemented in the controller by requiring COR and PL to be present for a finite period of time before recognizing the received signal, switching on the audio and keying the transmitters. This delay is referred to as the receive qualify delay. A future direction may provide for adaptive lengthening of this delay to provide a more effective anti-kerchunk mechanism.

Several things happen when the received signal drops out. The audio switches are turned off to mute the audio from that receiver. The transmit key down delay is started, to turn off the transmitter after a delay of a few seconds. In the case of a local repeater input (“remote”), a key up telemetry delay is started to transmit key up telemetry after a delay of about a second. Incoming signals will often be marginal, due to rapid mobile flutter or weak signals from a distant handheld. It is desirable to avoid cutting off audio, transmitting key up telemetry, or cutting off the transmitters during a noisy transmission. This is handled by introducing a second delay after COR or COR and PL is lost before the controller recognizes that the received signal has dropped out. In the case of a link receiver, in which the transmitter and receiver are in a fixed location, with the link designed for high signal to noise, then this delay should be 0. In the case of a repeater input, it needs to be some fraction of a second, depending upon the behavior of the receiver COR, PL, and squelch circuits. This delay is referred to as the received unqualify delay.

Key up telemetry is sent following a delay after received signal from a local repeater drops out. An option is provided to abort the key up telemetry if the received signal comes back on before the delay timeout. This prevents momentary loss of signal during a mobile flutter from repeatedly sending key up telemetry, independent of the value of the receive unqualify delay.

Both delays may be set independently for each receiver.

A weak signal may not provide a reliable PL signal. If PL is on, this can cause the audio switches to mute the weak audio. The receive unqualify delay should be set to prevent this from happening, while still providing the protection from passing grunge or undesirable keying of the transmitter.

If the audio from the receiver is not squelched, a long squelch tail will be heard between the loss of carrier and the receiver unqualify delay timeout. There is an option to shut off

the audio switch immediately on loss of carrier (squelch mute), to prevent this. Its undesirable side effect is that if the COR is not sufficiently sensitive, it may cut off the audio of a weak signal during fades. This option may be selected independently for each receiver.